

DATA SHEET

PULSATION DAMPENERS



Carbon Steel Model: **6011**

Carbon Steel/Stainless Steel Models: **6018, 6022**



FEATURES

- Nitrogen pre-charged to eliminate moisture and bladder deterioration.
- Broader bladder design provides greater pulsation reduction for smoother performance and longer system component life.
- Sealed valve for positive pressure lock

SHIPMENT REGULATIONS

- Pre-charged pulsation dampeners are defined as hazardous articles. **These articles use the proper shipping name of "Articles, Pressurized, Hydraulic" and use the identification number of "UN3164."**
- Uncharged pulsation dampeners require no special handling and can be shipped via standard shipping methods.
- All domestic shipments of hazardous articles must follow Department of Transportation CFR 49, parts 100 to 185 regulations (DOT).
- International shipments of hazardous articles must follow either International Air Transport Association regulation (IATA) or International Maritime Dangerous Goods Codes (IMDG).

ORDERING INFORMATION

Use base part number for rechargeable models 6011, 6018, 6022 if factory pre-charge is desired.

Add .800 to base part number for rechargeable models (i.e. 6018.800) for:

1. No pre-charge (remove factory pressure)
2. A pre-charge different from factory (indicate desired pre-charge on purchase order)

Note: A handling charge will apply.

SPECIFICATIONS

	U.S.	Metric
Model 6011 - Rechargeable		
Maximum Flow	25 gpm	95 lpm
Maximum Working Pressure	7200 psi	496 bar
Pre-charge	2000 psi	138 bar
Maximum Operating Temperature	180° F	82° C
Volume	15 cu. in.	0.25 L
Safety Factor	4/1	4/1
Bladder Construction	NBR	NBR
Lower Body (Wetted Parts)	Carbon Steel	Carbon Steel
Port Size	1/2" NPT(F)	1/2" NPT(F)
Diameter	4.5"	115 mm
Length	5.59"	142 mm
Weight	6.4 lbs.	2.9 kg

Model 6018 - Rechargeable

Maximum Flow	40 gpm	151 lpm
Maximum Working Pressure	3000 psi	207 bar
Pre-charge	450 psi	31 bar
Maximum Operating Temperature	180° F	82° C
Volume	45 cu. in.	0.74 L
Safety Factor	4/1	4/1
Bladder Construction	NBR	NBR
Lower Body (Wetted Parts)	SS	SS
Upper Body	Carbon Steel	Carbon Steel
Port Size	1" NPT(M)	1" NPT(M)
Diameter	4.78"	121 mm
Length	7.57"	192 mm
Weight	7.28 lbs.	3.3 kg

Model 6022 - Rechargeable

Maximum Flow	70 gpm	265 lpm
Maximum Working Pressure	1500 psi	103 bar
Pre-charge	450 psi	31 bar
Maximum Operating Temperature	180° F	82° C
Volume	120 cu. in.	1.97 L
Safety Factor	4/1	4/1
Bladder Construction	NBR	NBR
Lower Body (Wetted Parts)	SS	SS
Upper Body	Carbon Steel	Carbon Steel
Port Size	1 1/4" NPT(M)	1 1/4" NPT(M)
Diameter	6.25"	158 mm
Length	8.88"	225 mm
Weight	9.3 lbs.	4.2 kg

INSTALLATION INSTRUCTIONS

⚠ WARNING

Do not charge pulsation dampeners with oxygen. Oxygen may cause an explosion causing personal injury, death or property damage.

1. Use nitrogen only when charging pulsation dampeners, DO NOT USE OXYGEN.
2. Use proper charging tools to charge pulsation dampeners.
3. Charge pulsation dampener within specifications stated on data sheet to assure proper pulsation dampening and prevent failure of bladder.

SELECTION: The pulsation dampener should be selected to match the flow and pressure requirements of the system and satisfy the liquid compatibility.

INSTALLATION: The pulsation dampener should be mounted directly onto the pump discharge manifold for optimum pulsation dampening and to avoid system vibration damage. Before installing the pulsation dampener, be certain the sealed valve at the top of the pulsation dampener is securely tightened to assure no loss of pressure during operation.

OPERATION: The pulsation dampener should be pre-charged with **dry Nitrogen only**.

Note the standard pre-charge of the pulsation dampener. This may be adjusted to offer a more precise control of pulsation in critical applications such as reverse osmosis. Check this pre-charge every 12 months for normal operation and more frequently for continuous-duty operation.

At a standard temperature of 70°F optimum accumulator performance is obtained when the pre-charge is calibrated at 50% of the system operating pressure.

NOTE: When operating at the lower temperatures, pre-charge should be 15% higher or 65% of system pressure. When operating at higher temperatures, pre-charge should be 15% lower or 35% of system pressure.

NOTE: Up to 50 psi pre-charge pressure can be lost during the checking of your pre-charge.

DIMENSIONAL

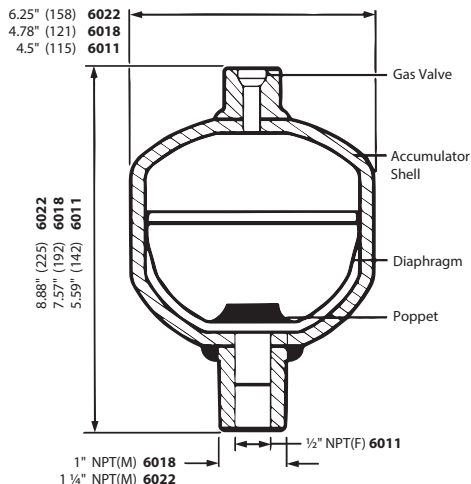

⚠ CAUTIONS AND WARNINGS

All High-Pressure Systems require a primary pressure regulating device (i.e. regulator, unloader) and a secondary pressure relief device (i.e. pop-off valve, relief valve). Failure to install such relief devices could result in personal injury or damage to pump or property. Cat Pumps does not assume any liability or responsibility for the operation of a customer's high-pressure system.

Read all CAUTIONS and WARNINGS before commencing service or operation of any high-pressure system. The CAUTIONS and WARNINGS are included in each Service Manual and with each Accessory Data sheet. CAUTIONS and WARNINGS can also be viewed online at www.catpumps.com/dynamic-literature/cautions-and-warnings or can be requested directly from Cat Pumps.

WARRANTY

View the Limited Warranty on-line at www.catpumps.com/warranty.

FILLING AND GAUGING INSTRUCTIONS

The following are the steps in both checking the pre-charge of the pulsation dampener and recharging if there should be a loss of pressure or a need for adjustment.

NOTE: A gas regulator must be mounted between the nitrogen tank and the hose connection from the Filling and Gauging Assembly to enable you to regulate 50% of the desired system pressure and to prevent excessive pressure being transmitted directly to the pulsation dampener. Over pressurization will void the warranty.

1. Before checking your pre-charge, system pressure should be at zero, turn system off.
2. Slightly loosen the sealed valve at the top of the pulsation dampener using a 6 mm long handled allen wrench. Thread on the Filling and Gauging Assembly hand tight.
3. Be certain the side bleed valve on the gauging assembly is closed.
4. Slowly open the large "T" valve at the top of the gauging assembly until completely open. The gauge on the assembly will read the pre-charge on the pulsation dampener.
5. Completely back off (close) the valve on the gas regulator, open the nitrogen tank valve and read the nitrogen tank pressure on the first gauge.
6. If the reading on the gauge assembly is 50% of the system pressure, close the top "T" valve and proceed to step 9.
7. If the pre-charge is too high, keep the top "T" valve open and slowly open the small "T" valve on the side of the gauging assembly to bleed off pressure.
8. If the pressure is less than 50% of the system pressure, slowly open the gas regulator valve until the desired pre-charge is reached on the second gauge.
9. When the gauge reads the required pre-charge, close the "T" valve on the top of the gauging assembly to lock the pre-charge in the pulsation dampener.
10. Back off (close) the gas regulator.
11. Proceed with opening the small side "T" valve on the gauging assembly to relieve (bleed-off) pressure in the assembly and on the second gauge on the gas regulator.
12. Close the side "T" valve on the gauging assembly and remove the assembly from the pulsation dampener.
13. Tighten the pulsation dampener sealed valve and resume operation.

OPTIONAL TOOLS AND SPARE PARTS

- 30940 Complete Filling and Gauging Assembly (Optional)
- 30941 Allen Wrench (Included in Assembly)
- 6099 Pressure Gauge (Included in Assembly)
- 76501 Charging Screw w/Seal Washer

