

Stainless Steel Pressure Regulator

Models

**7061, 7063, 7073
7095, 7096, 7097**

FEATURES

- Maintains full system pressure while running in idle.
- Offers pump protection against pressure fluctuations and system changes.
- Minimum pressure fluctuations with the alternating use of multiple guns and nozzles.
- Top adjusting handle and locking nut to secure exact pressure setting.
- No external moving parts. Stainless Steel and Viton® internal parts for temperature and liquid compatibility.

SPECIFICATIONS

	U.S. Measure	Metric Measure
MODEL 7061		
Flow Range	10-70 GPM	(38-265 L/M)
Pressure Range	400-1000 PSI	(30-70 BAR)
MODEL 7063		
Flow Range	10-70 GPM	(38-265 L/M)
Pressure Range	600-1800 PSI	(45-125 BAR)
MODEL 7073		
Flow Range	10-70 GPM	(38-265 L/M)
Pressure Range	1200-2000 PSI	(85-140 BAR)
MODEL 7095		
Flow Range	10-75 GPM	(38-284 L/M)
Pressure Range	400-1000 PSI	(30-70 BAR)
MODEL 7096		
Flow Range	10-75 GPM	(38-284 L/M)
Pressure Range	1000-2000 PSI	(70-140 BAR)
MODEL 7097		
Flow Range	10-75 GPM	(38-284 L/M)
Pressure Range	100-400 PSI	(7-30 BAR)

COMMON SPECIFICATIONS

Max. Temperature	180°F	(82°C)
Inlet Port	1" NPTF	(1" NPTF)
By-Pass Port	1-1/4" NPTF	(1-1/4" NPTF)
Weight	6.2 lbs.	(2.8 kg)
Dimensions	9.1 x 3.43 x 2.38"	(231 x 87 x 60.45 mm)

⚠ WARNING

All systems require both a primary pressure regulating device (i.e., regulator, unloader) and a secondary pressure safety relief device (i.e., pop-off valve, safety valve). Failure to install such relief devices could result in personal injury or damage to the pump or to system components. CAT PUMPS does not assume any liability or responsibility for the operation of a customer's high pressure system.

"Customer confidence is our greatest asset"

SELECTION: This **Pressure Regulator** is designed for systems with **single or multiple** pumps, solenoid (gate) valves, nozzles, standard or "weep" guns.

This regulator maintains established system pressure even when only one of several guns (nozzles) or solenoid (gate) valves is open or a nozzle is clogged, by-passing the unrequired flow.

It returns to established system pressure without delay upon squeezing the trigger gun(s) or opening the solenoid (gate) valve(s).

Select the specific model of regulator to meet both the desired system flow (combined nozzle flow rate requirement) and the desired system pressure.

Exercise caution when matching the system requirements to the regulator flow capacity and pressure rating. Operation below the minimum flow of the regulator causes the regulator to cycle or chatter. Operation beyond the rated regulator flow causes premature valve wear, regulator cycling and prevents attaining desired system pressure.

Select a high pressure nozzle sized to provide for both the desired **system flow** and pressure and **regulator by-pass**.

CAUTION

A MINIMUM BY-PASS FLOW of 10% of the REGULATOR RATED FLOW CAPACITY is required for proper regulator performance.

When properly set this regulator protects the pump from pressure extremes associated with obstructions in the discharge line, while maintaining the established system pressure. When no flow is required by the system, the regulator by-passes all the system flow, but holds system pressure in the discharge line [between the regulator and gun(s) or solenoid valve(s)] **and at the pump** head ready for a quick return to high pressure operation.

INSTALLATION: This regulator operates properly when mounted in any direction, however, it is preferred to keep the plumbing to a minimum and the adjustment handle easily accessible. The best location is directly on the pump discharge manifold head. Plumbing to and from the regulator should be at least the size of the regulator ports and flexible, high pressure hose (minimum single wire braid) is required.

The standard **inlet connection** of this regulator is located at the **side**. The regulator can be mounted directly onto the discharge manifold head or "teed" into the discharge line.

The **by-pass connection** is on the **bottom** of the regulator and can be plumbed in one of the following methods. Note that prolonged by-pass can result in significant heat build-up and frequent by-pass can result in premature wear to the valve. A **MINIMUM BY-PASS OF 10%** is necessary for the regulator to operate properly.

CAUTION

If the entire output is directed through the regulator (zero by-pass) the "cushioning" feature of the by-pass liquid is eliminated and the regulator can malfunction or wear prematurely.

Check the amount of by-pass by disconnecting the by-pass line and measuring the flow into a graduated container.

By-Pass to Reservoir: Ideally the by-pass line should be directed to a reservoir with at least one baffle between the supply line to the pump (from the reservoir) and the return by-pass line (from the regulator into the reservoir). This baffle minimizes turbulence and air bubbles that could enter the pump inlet feed line. **The reservoir capacity should be 6 to 10 times the rated system flow per minute.**

By-Pass to Pump Inlet: Although not recommended, by-pass liquid can be returned to the inlet line of the pump or directly to a pump inlet port (**systems up to 10 GPM**). When using this method an *Inlet Pressure Regulator* should be installed on the inlet line to avoid excessive inlet pressure. Be certain the *Inlet Pressure Regulator* is **between** the pump inlet and the by-pass line connection. When using this method, a *Thermo Valve* should be installed in the by-pass line to protect the pump from temperature build-up and premature seal failure.

The by-pass line should be **connected to the pump inlet line at a gentle angle of 45° or less and no closer than 10 times the pump inlet port diameter** e.g. 1-1/2" port size = 15" distance from pump inlet port. **Refer to Technical Bulletin 064 for additional information on the size and length of the by-pass line.**

By-Pass to Drain: If the by-pass is limited and infrequent, the by-pass can easily drain to an unpressurized drain line (to the ground).

TYPICAL INSTALLATION

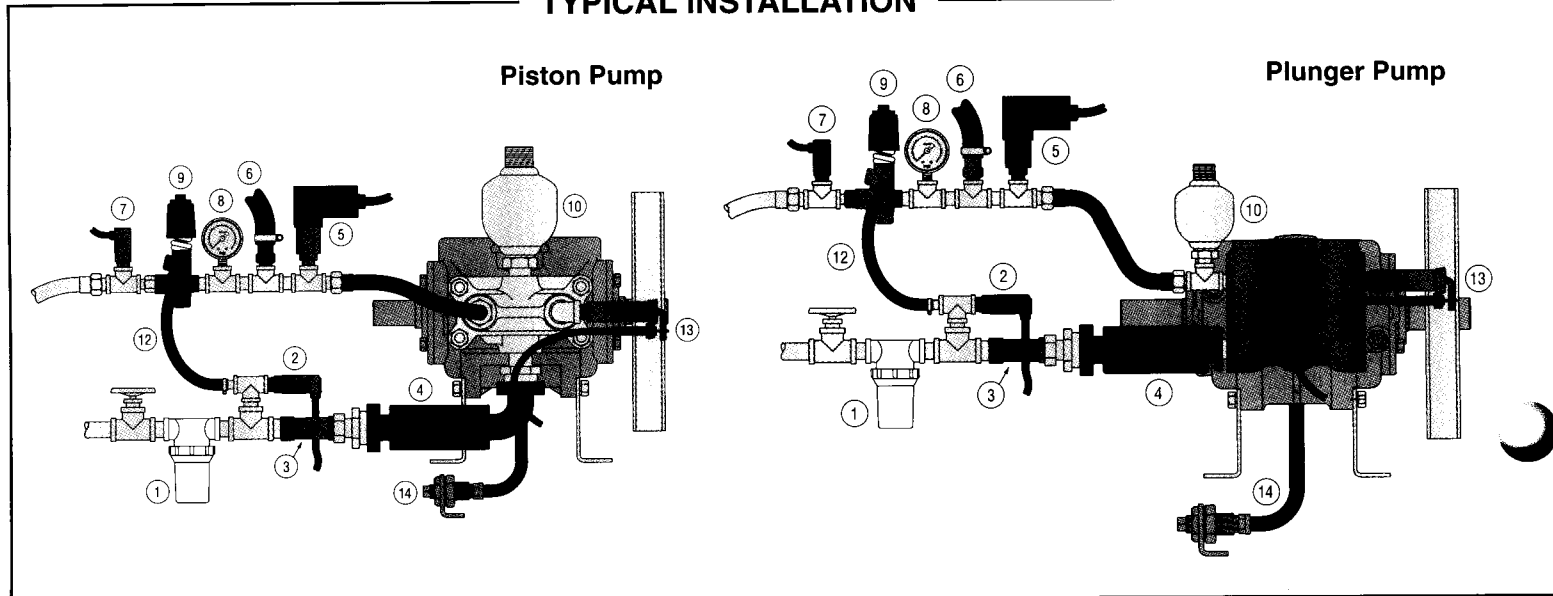

It is recommended that a secondary protective device such as the *CAT PUMP Pop-Off Valve* be installed to assure pump protection should the regulator malfunction. Refer to Troubleshooting for more information on malfunction of regulator.

Preferred mounting of the *Prrrrr-o-lator* (pulsation dampener) is directly on the **Discharge Manifold Head**. When using the *Inlet Pressure Regulator*, mount the *Prrrrr-o-lator* **downstream from the regulator** to assure optimum performance of the regulator.

CAUTION

Oversizing the *Prrrrr-o-lator* may cause delayed response from the regulator.

PRESSURE ADJUSTMENT: Setting and adjusting the regulator pressure must be done with the system "on". Start the system with the regulator backed off to the lowest pressure setting (**counterclockwise direction**). Squeeze the trigger and read the pressure on the gauge at the pump. **NOTE: Do not read the pressure at the gun or nozzle.** If more pressure is desired, release the trigger, turn adjusting handle one quarter turn in a **clockwise direction**. Squeeze the trigger and read the pressure. Repeat this process until desired system pressure is attained.

Once the desired system pressure is reached, stop turning the adjusting handle. Thread lock nut down to upper body. **NOTE: The lock nut is not set at the factory.**

If desired system pressure cannot be reached, review TROUBLESHOOTING chart.

When servicing existing systems, back lock nut away from upper body. Follow adjustment procedures as stated above for new regulators.

NOTE: Do not adjust regulator pressure setting to compensate for a worn nozzle. Check the nozzle as part of the regular maintenance and replace if worn.

Approximate Pressure Reading at Gauge	Gauge Between Pump/Regulator	Gauge Between Regulator/Gun-Nozz-Valve
System in operation (gun open)	system pressure	system pressure
System in by-pass (all guns, valves closed)	system pressure	system pressure

TROUBLESHOOTING

- | | |
|--------------------------------------|---|
| Cycling /Chattering | <ul style="list-style-type: none"> ● Too little flow for valve specifications. ● Air in system, poor connections. ● Inlet seals in pump worn. ● O-ring in gun worn. |
| System will not build up to pressure | <ul style="list-style-type: none"> ● Nozzle worn. ● Improper nozzle size for system specs. |
| Pressure drop | <ul style="list-style-type: none"> ● Nozzles worn. ● Piston and seat in regulator worn. ● Air in system, poor connections. ● Insufficient flow to pump. ● Filter clogged. Check and clean regularly. |
| Pressure spikes while in by-pass | <ul style="list-style-type: none"> ● Minimum by-pass of 10% not present. ● Excessive pressure adjustment made for worn nozzle. REPLACE NOZZLE. Reset system pressure. |
| Leakage from regulator vent hole | <ul style="list-style-type: none"> ● O-ring around piston worn. Replace. ● Piston Retainer scored. Replace. |

WARRANTY

90 Day Warranty

Refer to complete CAT PUMPS Warranty for further information.

- | | |
|---|----------------------------------|
| 1 Inlet Filter | 8 Pressure Gauge |
| 2 Thermo Valve | 9 Pressure Regulator/Unloader |
| 3 Inlet Pressure Regulator | 10 Pulsation Dampener★ |
| 4 C. A.T. Tube
(Captive Acceleration Tube) | 11 Chemical Injector (Not Shown) |
| 5 Pressure Switch | 12 By-pass Hose |
| 6 Pop-Off Valve | 13 Throttle Controller |
| 7 Quick Start Valve | 14 Oil Drain Kit |

★ Preferred mounting of Pulsation Dampener [Prrrrr-O-Lator] is directly on the discharge manifold of the pump. The preferred mounting of the by-pass hose [when returning to the inlet] is before the Pressure Reducing Valve. If this is not possible, then mount the Prrrrr-O-Lator after the Pressure Unloading Valve to prevent pressure spikes to the pump inlet.

These illustrations show the basic elements for a typical installation of a high pressure piston or plunger pump. **Not all components shown are required for all applications or systems.** Each component presents potential problems that too often are ascribed to a perfectly functioning pump, such as: a clogged strainer, a partially closed shut-off valve, a faulty gauge, or a malfunctioning regulator/unloader. Proper system installation, routine lubrication, monitoring and maintenance of components are your basic guarantees of optimum pump performance. CAT PUMPS does not assume any liability or responsibility for the design or operation of a customer's high pressure system.

EXPLODED VIEW

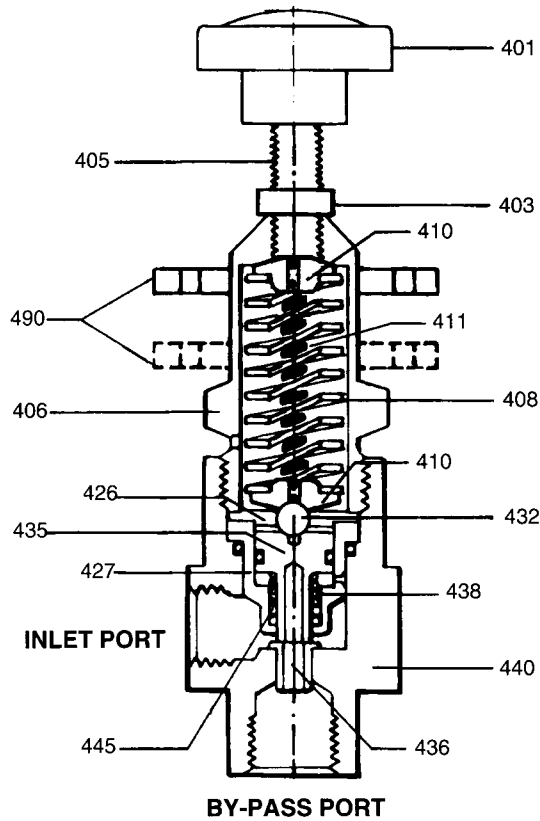

CUTAWAY

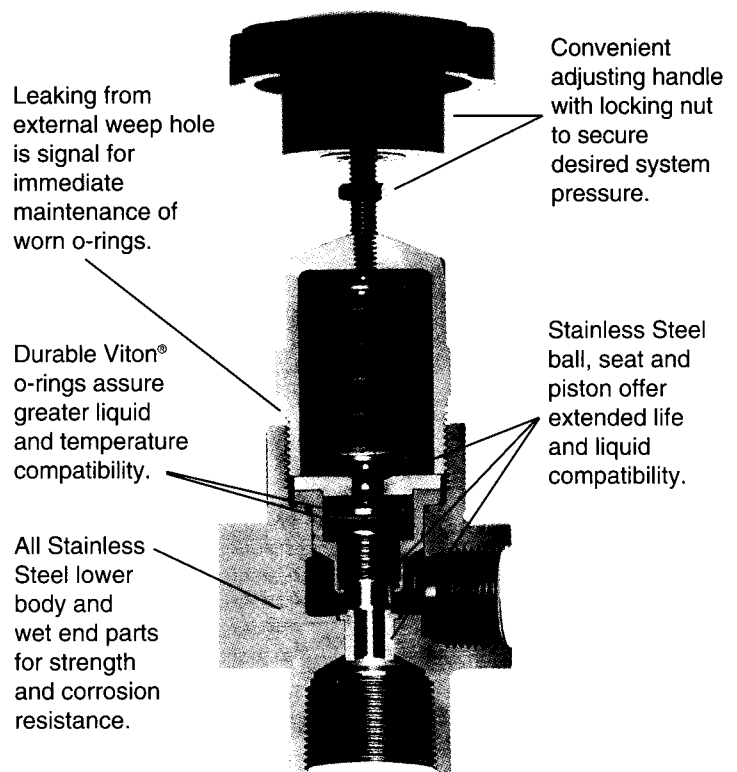

PARTS LIST

ITEM	DESCRIPTION	MODEL NUMBER												QTY
		7061	MATL	7063	MATL	7073	MATL	7095	MATL	7096	MATL	7097	MATL	
401	Handle, Adjusting	30948	NY	30948	NY	30948	NY	30948	NY	30948	NY	30948	NY	1
403	Nut, Lock	30933	S	30933	S	30933	S	30933	S	30933	S	30933	S	1
405	Adjuster, Pressure	30932	S	30932	S	30932	S	30932	S	30932	S	30932	S	1
406	Body, Upper	30928	BBNP	30928	BBNP	30928	BBNP	30928	BBNP	30928	BBNP	30928	BBNP	1
408	Spring	30935	S	30946	S	30946	S	30935	S	30946	S	39946	S	1
410	Retainer, Spring	34289	BB	34289	BB	34289	BB	34289	BB	34289	BB	34289	BB	2
411	Spring, Inner	—	—	—	—	34296	S	—	—	—	—	—	—	1
426	Guide, Piston	30927	BBCP	30927	BBCP	30927	BBCP	30927	BBCP	30927	BBCP	39927	BBCP	1
427	Insert, Piston	30926	SS	30926	SS	30926	SS	30926	SS	30926	SS	39926	SS	1
432	Ball, Seat	30936	SS	30936	SS	30936	SS	30936	SS	30936	SS	30936	SS	1
435	Piston	30924	SS	30924	SS	30924	SS	34171	SSSS	34292	SSSS	39936	SSSS	1
436	Seat	30918	S	30918	S	30918	S	34190	SSSS	34297	SSSS	39997	SSSS	1
438	Spring, Seat	30934	S	30934	S	30934	S	30934	S	30934	S	39934	S	1
440	Body, Lower Hex	33917	SS	33917	SS	33917	SS	33917	SS	33917	SS	33917	SS	1
445	Washer, Flat	30925	SS	30925	SS	30925	SS	30925	SS	30925	SS	39925	SS	1
468	Kit, O-Ring	30950	FPM	30950	FPM	30950	FPM	30950	FPM	30950	FPM	39950	FPM	1
490	Bracket, Panel Mount	30947	BB	30947	BB	30947	BB	30947	BB	30947	BB	—	—	1

Bold print part numbers are unique to a particular model. *Italics are optional items.*

MATERIAL CODES (Not Part of Part Number):

BB=Brass BBCP=Brass/Chrome Plated BBNP=Brass/Nickel Plated FPM=Fluorocarbon (Viton®) NY=Nylon S=304SS SS=316SS SSSS=440SS

World Headquarters

CAT PUMPS

1681 - 94th Lane N.E. Minneapolis, MN 55449-4324

Phone (763) 780-5440 — FAX (763) 780-2958

e-mail: techsupport@catpumps.com

www.catpumps.com

International Inquiries

FAX (763) 785-4329

e-mail: intl@catpumps.com



The Pumps with Nine Lives

CAT PUMPS (U.K.) LTD.

1 Fleet Business Park, Sandy Lane, Church Crookham, Fleet

Hampshire GU52 8BF, England

Phone Fleet 44 1252-622031 — Fax 44 1252-626655

e-mail: sales@catpumps.co.uk

N.V. CAT PUMPS INTERNATIONAL S.A.

Heiveldekens 6A, 2550 Kontich, Belgium

Phone 32-3-450.71.50 — Fax 32-3-450.71.51

e-mail: cpi@catpumps.be www.catpumps.be

CAT PUMPS DEUTSCHLAND GmbH

Buchwiese 2, D-65510 Idstein, Germany

Phone 49 6126-9303 0 — Fax 49 6126-9303 33

e-mail: catpumps@t-online.de www.catpumps.de