



# Misting, Cooling and Fogging Equipment

Exceptional Life for any Environmental System



Product Quality, Reliability and Support You Expect

[www.catpumps.com](http://www.catpumps.com)



Photo provided by Atomizing Systems Inc.

# Cat Pumps Keeps You Cool, Clean, and in Control

Atomized water keeps customers and computer servers cool, potatoes and lumber humid, and amusement parks fun. From poultry farms to greenhouses, high-pressure misting contributes to happy egg-laying hens and green, growing plants. But the opposite is also true: poor heat and humidity control can lead to overheating, loss of service or product, and many unhappy customers.

Equipment builders and system users stake their reputation on system performance. Lost time, production, and customer satisfaction cannot be recovered. This is one reason why Cat Pumps is the leading pump and power unit provider to the industry. With over 47 years of high-pressure pump manufacturing, Cat Pumps has built a solid reputation of producing the highest quality, longest-lasting pumps.

Quality is never an accident. Cat Pumps has engineered every last detail of pump design for long-life and reliable performance. When service is necessary, repairs can be made fast without special tools. Cat Pumps stocks service kits and parts for off-the-shelf delivery, plus is supported by a strong worldwide distribution network.



Photo provided by Atomizing Systems Inc.

**Make every hour count with Cat Pumps. Enjoy these benefits:**

- Higher productivity and better yields
- Better system performance with less downtime
- Greater confidence in equipment and system performance

# Designed and Built for Dependable Performance and Long-Life

Quality is evident in every design detail of Cat Pumps products. Equipment builders and leading users specify Cat Pumps to keep equipment running to meet uptime goals and high production yields.

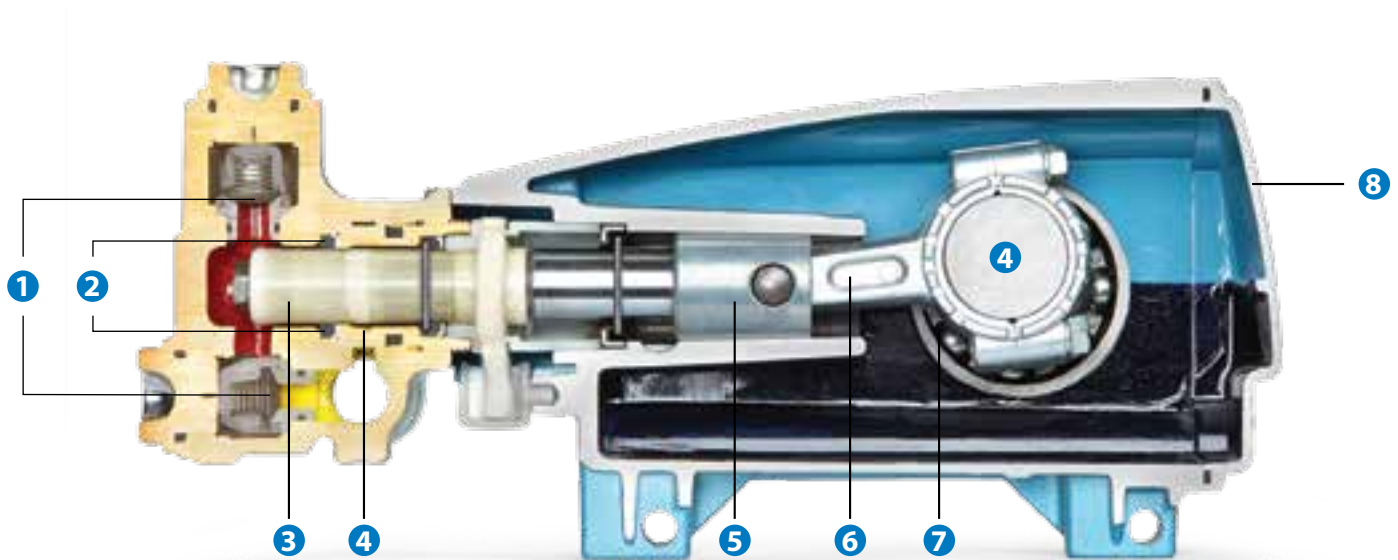

- 1 Stainless steel valves, seats and springs provide corrosion-resistance, positive seating and long life.
- 2 Specially formulated, Cat Pumps exclusive high-pressure seals offer unmatched performance and seal life.
- 3 Precision-polished, solid ceramic plungers provide maximum resistance to corrosion and abrasion, extending seal life.
- 4 100% wet seal design adds to service life by allowing pumped fluids to cool and lubricate the elastomers on both sides.
- 5 The high-strength stainless steel plunger rods have a 360° supported crosshead providing uncompromising plunger rod alignment.
- 6 Matched oversized connecting rods are made of high-strength material with exceptional bearing quality.
- 7 Oversized ball bearings or tapered roller bearings provide extended bearing life.
- 8 High-strength, lightweight die cast aluminum crankcase with splash oil design allows operation at speeds as low as 100 rpm.

# Industry Applications

## Humidity/Moisture Control

Misting or fogging systems are commonly used to maintain proper moisture and/or consistent humidity. They eliminate static electricity, suspend airborne dust, and ensure that product and materials are less susceptible to brittleness and fracturing.

### Typical Applications:

- Nurseries
- Greenhouses
- Air handling units at Hospitals and Universities
- Poultry Hatchery
- Vegetable Storage
- Wine Barrel Storage
- Meat Processing Rooms
- Textile/Paper Processing
- Print shops
- Concrete Curing
- Lumber Conditioning



## Evaporative Cooling/Temperature Control

High-pressure mist cooling uses a high-pressure pump system and nozzles to inject atomized water into the air. The results of this type of cooling are dramatic and can reduce air temperature by 20 to 30 degrees depending upon ambient conditions.

### Typical Applications:

- Outdoor dining and waiting areas
- Hotels, resorts, and theme parks
- Sporting events
- Warehouses and loading docks
- Poultry barns
- Recreational areas
- Kennels and veterinary hospitals
- Livestock cooling
- Universities and libraries
- Site tents for personnel cooling



Photo provided by Modern Misting Systems Inc.

## Odor and Pest Control

Misting/fogging systems are commonly used in eliminating unwanted odors and pests. The reduction of water and chemicals lowers costs, making misting a great choice for odor and pest control.

### Typical Applications:

- Recycling and landfills
- Waste transfer stations
- Trash collection sites
- Water treatment facilities
- Rendering plants
- Food waste sites
- Livestock and poultry sites
- Sanitation
- Paper mills
- Mosquito misting



Photo provided by Atomizing Systems Inc.

## Special Effects

Misting/fogging systems are used to simulate fog or smoke and create excitement or intrigue. Misting/fogging systems are a great way to improve the customer experience, create visual effects and drive additional revenue from customer visits.

### Typical Applications:

- Theme parks
- Zoos
- Hotels and resorts
- Stadiums
- Gardens
- Pool areas
- Motion picture productions
- Concerts



Photo provided by Atomizing Systems Inc.

## Mist Dust Suppression

Misting/fogging is used to control the amount of dust particles in the air. Misting suppresses or removes breathable dust particles, improving air quality and working conditions. Misting also results in equipment life improvement.

### Typical Applications:

- Mining
- Conveyor systems
- Crushing and grinding
- Demolition
- Steel mills
- Stockpiles
- Grain and powder transfer
- Livestock buildings



Photo provided by Modern Misting Systems Inc.

## Process Cooling

Process cooling refers to the use of high pressure mist cooling in manufacturing, power generation, and HVAC. Misting systems benefits can dramatically improve the quality of products and working environment while reducing production downtime. Example: fogging systems used to cool gas turbines can increase output up to 20%.

### Typical Applications:

- Gas turbine cooling
- HVAC systems
- Cooling towers
- Equipment and electronic rooms
- Manufacturing plants
- Injection molding
- Steel casting-machining
- Food processing
- Air scrubbing
- Computer server farms



Photo provided by Atomizing Systems Inc.

# Compact Misting Pumps

The high-pressure water pump is the most important part of a misting system. This is why customers select products such as the 1CX series pump from Cat Pumps. The 1CX is an incredibly reliable pump designed to keep your equipment running. From the oil lubricated drive-end to the specially designed regulator, engineers at Cat Pumps set out to design the best compact misting pump available.

The 1CX is the perfect fit for misting applications that require 0.5 gpm or less. With seals that last thousands of hours before requiring any servicing, the 1CX is small in size but has the same life expectancy as our industrial products.



## Model Number Selection Chart

Series	Flow (1750 rpm)	Regulator	Assemble Option	Motor Option*	Pulse Hose Option
1CX	013 = .13 gpm	R = Regulator Included	D = Pump and Motor shipped together – not assembled	1 = 8180	Blank = No Pulse Hose
	025 = .25 gpm			2 = 8182	
	050 = .5 gpm		A = Pump and Motor assembled together	3 = 8185	P = Pulse Hose Included
				4 = 8183	

**Example:** 1CX050RA2P = .5 gpm, Regulator, 8182 Motor, Assembled, Pulse Hose included

### \*Motor Options:

- |   |   |
|---|---|
| 1. 8180 – 1/4 hp, 115/230 V, 60Hz, 1ph, 1750 rpm, 12 inch leads | 2. 8182 – 1/2 hp, 115/230 V, 60Hz, 1ph, 1750 rpm, 12 inch leads |
| 3. 8185 – 1/2 hp, 115/230 V, 60Hz, 1ph, 1750 rpm, terminal box  | 4. 8183 – 1/2 hp, 115/230 V, 50Hz, 1ph, 1450 rpm, terminal box  |

“The applications I serve often require the pumps to perform at the edge of their operating limits. Cat Pumps are the only pumps that can handle the application variation and still meet the demands in life that customers need.”

Ali Erturk • Aniks

# Direct-Drive Hollow Shaft Pumps

When it comes to getting the job done, customers rely on durable long-lasting products from Cat Pumps. The direct-drive hollow shaft pumps are no exception. Designed for continuous duty applications and built to Cat Pumps quality standards, these pumps are preferred by system builders due to their compact size and ease of assembly.

From specially formulated high-pressure seals to concentric polished ceramic plungers, Cat Pumps direct-drive pumps provide maximum life. Compact hollow shaft design is a perfect match for standard NEMA 56C frame electric motors. Flow rates from 0.5 to 3.5 gpm; pressures from 300 to 2000 psi.



## Brass Manifold, 1725 RPM

Electric Motor, 5/8", 56C Face

Pump Model	Max. flow		Max pressure		rpm	Shaft	Power	
	gpm	lpm	psi	bar			hp	kW
4DX10ER	0.5	1.9	2,000	138	1725	5/8"	0.7	0.5
4DX15ER	0.75	2.9	2,000	138	1725	5/8"	1.0	0.8
4DX20ER	1	3.8	2,000	138	1725	5/8"	1.4	1.0
4DX27ER	1.35	5.1	2,000	138	1725	5/8"	1.8	1.4
4DX30ER	1.5	5.7	2,000	138	1725	5/8"	2.1	1.5
4SP21EL	2.1	8.0	2,000	138	1725	5/8"	2.9	2.1
2SF25ELS	2.5	9.5	1,500	103	1725	5/8"	2.6	1.9
2SF29ELS	2.85	10.8	1,500	103	1725	5/8"	2.9	2.2

## Brass Manifold, 3450 RPM

Electric Motor, 5/8", 56C Face

Pump Model	Max. flow		Max pressure		rpm	Shaft	Power	
	gpm	lpm	psi	bar			hp	kW
4DX10ER	1	3.8	2,000	138	3450	5/8"	1.4	1.0
4DX15ER	1.5	5.7	2,000	138	3450	5/8"	2.1	1.5
4DX20ER	2	7.6	2,000	138	3450	5/8"	2.7	2.0
4DX27ER	2.7	10.3	2,000	138	3450	5/8"	3.7	2.7
4DX30ER	3	11.4	2,000	138	3450	5/8"	4.1	3.0
2SF35ES	3.5	13.3	1,500	103	3450	5/8"	3.6	2.7

# Direct-Drive Bell Housing Pumps

Bell housing mounting is designed for easy assembly and compact size, with a smaller footprint compared to belt-drive units. Cat Pump bell housings are made from high strength aluminum and anodized for optimal corrosion resistance.

Pump options for direct-drive bell housings include brass and 316 stainless steel manifolds. Available flow rates: 2.3 to 10.5 gpm, with pressures up to 4000 psi. Bell housings are available as individual components or assembled as complete pump/motor assemblies. Maximum horsepower: 20/256TC frame motors.



## Brass Manifold, 1725 rpm

Electric Motor - Bell Housing

Pump Model	Max. flow		Max pressure		rpm	Shaft	Power	
	gpm	lpm	psi	bar			hp	kW
3CP1130	2.4	9.1	2,000	138	1725	16.5 mm	3.3	2.4
3CP1140	3.6	13.7	2,200	152	1725	16.5 mm	5.4	4.0
5CP2140WCS	4	15.2	2,500	172	1725	20 mm	6.8	5.1
3CP1120	4.2	16.0	2,200	152	1725	16.5 mm	6.3	4.7
5CP4120CSS	4.5	17.1	4,000	276	1725	20 mm	12.3	9.1
5CP3120CSS	4.8	18.2	3,000	207	1725	20 mm	9.9	7.3
5CP2150W	5	19.0	2,000	138	1725	20 mm	6.8	5.1
5CP5120	6	22.8	2,500	172	1725	20 mm	10.3	7.6
5CP6120	7.4	28.1	1,200	83	1725	20 mm	6.1	4.5
56	8	30.4	2,500	172	1725	24 mm	13.7	10.1
5CP6190	9.7	36.9	1,200	83	1725	20 mm	8.0	5.9
7CP6110	10.5	39.9	2,000	138	1725	24 mm	14.4	10.6

## 316 Stainless Steel Manifold, 1725 rpm

Electric Motor - Bell Housing

Pump Model	Max. flow		Max pressure		rpm	Shaft	Power	
	gpm	lpm	psi	bar			hp	kW
3CP1231	2.3	8.7	2,000	138	1725	16.5 mm	3.2	2.3
3CP1241	3.6	13.7	2,000	138	1725	16.5 mm	4.9	3.6
5CP6241CS	4	15.2	2,000	138	1725	20 mm	5.5	4.1
3CP1221	4.2	16.0	2,000	138	1725	16.5 mm	5.8	4.3
5CP6251	5	19.0	2,000	138	1725	20 mm	6.8	5.1
5CP6221	7.4	28.1	1,200	83	1725	20 mm	6.1	4.5
7CP6111	10.5	39.9	2,000	138	1725	24 mm	14.4	10.6



# Direct-Drive Mounting Components

## Bell Housing Assembly

Pump Series	Models	Motor Frame	Bell Housing Assy
3CP Series	3CP1120 - 40, 3CP1231 - 41	56C - 145TC	76056.3CP
		182/184TC	76184.3CP
		213/215TC	76215.3CP
3FR Series	230 - 270, 231 - 241, 237 - 247	56C - 145TC	76056.3FR
		182/184TC	76184.3FR
		213/215TC	76215.3FR
5CP Series	5CP3110CSS - 5CP6190, 5CP6221 - 5CP6251	56C - 145TC	76056.5CP
		182/184TC	76184.5CP
		213/215TC	76215.5CP
		254/256TC	76256.5CP
5FR Series	340 - 350, 341 - 351, 347 - 357	182/184TC	76184.5FR
		213/215TC	76215.5FR
7CP Series	7CP6110, 7CP6111	182/184TC	76184.7CP
		213/215TC	76215.7CP
		254/256TC	76256.7CP
7FR/8FR Series	56, 60, 700, 781, 781K	213/215TC	76215.7FR
		254/256TC	76256.7FR



Bell Housing Series

## Flexible Coupler Assembly

Pump Series	Motor Frame	Flex Coupler Assy	HP Rating
3CP & 3FR Series	56C	8215	3
	145TC	8210	3
	182/184TC	8220	3
	182/184TC	8225	10
	213/215TC	8270	20
5CP & 5FR Series	56C	8261	10
	145TC	8260	10
	182/184TC	8230	10
	213/215TC	8275	20
7CP & 7FR Series	254/256TC	8217	20
	182/184TC	8370	10
	213/215TC	8375	10
	254/256TC	8380	20



Flex Coupler Series

# Belt Drive Pumps

Belt drive pumps offer longer life by running at slower speeds, reducing pump wear. For continuous duty applications, an oversized pump running slower can provide up to 10,000 hours of operation before needing seal or valve servicing.

Cat Pumps belt-driven pumps can be configured to obtain exact performance required. With the flexibility of varying pulley ratios, flow can be selected regardless of motor or pump rpm. Options include low-speed 8-pole motors to high-speed 2-pole motors, 50 or 60 Hz. Special motor requirements and belt drive packages are also available.



## Brass Manifold

Pump Model	Max. flow		Max pressure		Max rpm	Shaft	Power	
	gpm	lpm	psi	bar			hp	kW
3CP1130	2.4	9.1	2,000	138	1725	16.5 mm	3.3	2.4
3CP1140	3.6	13.7	2,200	152	1725	16.5 mm	5.4	4.0
5CP2120W	4	15.2	2,500	172	950	20 mm	6.8	5.1
3CP1120	4.2	16.0	2,200	152	1725	16.5 mm	6.3	4.7
5CP3120	4.5	17.1	3,500	241	1645	20 mm	10.8	8.0
5CP2150W	5	19.0	2,000	138	1725	20 mm	6.8	5.1
5CP6120	7.4	28.1	1,200	83	1725	20 mm	6.1	4.5
56	8	30.4	2,500	172	1725	24 mm	13.7	10.1
5CP6190	9.7	36.9	1,200	83	1725	20 mm	8.0	5.9
1050	10	38.0	2,200	152	958	30 mm	15.1	11.2
7CP6170	10.5	39.9	2,000	138	1450	24 mm	14.4	10.6
1050	12	45.6	1,800	124	1150	30 mm	14.8	10.9
1530	15.6	59.3	1,500	103	1450	30 mm	16.0	11.9
1540E	18	68.4	1,200	83	1100	30 mm	14.8	10.9
2510	20	76.0	2,000	138	1450	30 mm	27.4	20.3
3520	23	87.4	2,000	138	800	35 mm	31.5	23.3
2530	25	95.0	1,000	69	1025	30 mm	17.1	12.7
3535	36	136.8	1,200	83	800	35 mm	29.6	21.9
3545	45	171.0	1,000	69	765	35 mm	30.8	22.8
3545HS	50	190.0	1,500	103	850	35 mm	51.4	38.0
6760	60	228.0	1,200	83	520	45 mm	49.3	36.5
6775	75	285.0	1,200	83	650	45 mm	61.6	45.6

## 316 Stainless Steel Manifold

Pump Model	Max. flow		Max pressure		Max rpm	Shaft	Power	
	gpm	lpm	psi	bar			hp	kW
3CP1231	2.3	8.7	2,000	138	1725	16.5 mm	3.2	2.3
3CP1241	3.6	13.7	2,000	138	1725	16.5 mm	4.9	3.6
5CP6241CS	4	15.2	2,000	138	1725	20 mm	5.5	4.1
3CP1221	4.2	16.0	2,000	138	1725	16.5 mm	5.8	4.3
5CP6251	5	19.0	2,000	138	1725	20 mm	6.8	5.1
5CP6221	6	22.8	2,000	138	1400	20 mm	8.2	6.1
1051	10	38	2,200	152	958	30 mm	15.1	11.2
7CP6171	10.5	39.9	2,000	138	1450	24 mm	14.4	10.6
1051	12	45.6	1,800	124	1150	30 mm	14.8	10.9
1531	15.6	59.28	1,500	103	1450	30 mm	16.0	11.9
1541	18	68.4	1,200	83	1100	30 mm	14.8	10.9
2511	20	76	1,500	103	1450	30 mm	20.5	15.2
3521	23	87.4	2,000	138	800	35 mm	31.5	23.3
2531	25	95	1,000	69	1025	30 mm	17.1	12.7
3531	36	136.8	1,200	83	800	35 mm	29.6	21.9
3531HS	40	152	2,000	138	888	35 mm	54.8	40.5
3541	45	171	1,000	69	765	35 mm	30.8	22.8
6761	60	228	1,200	83	520	45 mm	49.3	36.5
6771	75	285	1,200	83	650	45 mm	61.6	45.6

“Cat Pumps have been installed in our botanical garden’s fogging system for years. We never touch them which are important with our small maintenance staff.”

Ken Henderson • Minnesota Zoo

# Flush-Style Pumps

Flush pumps (“K” or “C” option) provide an external seal flush between the high and low pressure seals, adding considerable life to seals and wear elements.

Flush pumps are ideal for applications that pump liquids with poor lubricity properties, such as demineralized or highly purified water, which is often used for inlet turbine fogging. Clean room humidification can also use demineralized water/ high-purity water.

Cat Pumps products have been used with confidence for years on applications with low lubricity fluids. Contact Cat Pumps application specialists to properly size and select pumps and accessories, including power unit system design.



## 316 Stainless Steel Manifold

Pump Model	Max. flow		Max pressure			Shaft	Power	
	gpm	lpm	psi	bar	rpm		hp	kW
311C	4	15.2	2,200	152	950	20 mm	6.0	4.5
781K	4.5	17.1	5,000	345	1700	24 mm	15.4	11.4
1051C	10	38	2,200	152	958	30 mm	15.1	11.2
7CP6171C	10.5	39.9	2,000	138	1450	24 mm	14.4	10.6
3511C	14	53.2	3,000	207	800	35 mm	28.8	21.3
2831K	21	79.8	1,200	83	860	30 mm	17.3	12.8
3521C	23	87.4	2,000	138	800	35 mm	31.5	23.3
6821K	25	95	3,000	207	615	45 mm	51.4	38.0
3531C	36	136.8	1,200	83	800	35 mm	29.6	21.9
6831K	40	152	2,300	159	625	45 mm	63.0	46.6
3541C	45	171	1,000	69	765	35 mm	30.8	22.8
6841K	48	182.4	2,000	138	615	45 mm	65.8	48.7
6861K	60	228	1,200	83	52	45 mm	49.3	36.5

# Custom Pumping Systems

For over 25 years, Cat Pumps has been the industry leader in providing custom-engineered pumping systems to meet a wider range of application needs. By selecting Cat Pumps for your next pumping system, customers eliminate the hassle and expense of designing, multiple source buying, fabrication and testing. The technical sales team assists with proper component selection, as well as installation, operation and maintenance support.

All systems are designed, built and pressure tested in the Cat Pumps Minneapolis location. To begin the quoting process, call the main office at (763) 780-5440 or submit the custom system quote form at [catpumps.com](http://catpumps.com).

With thousands of installations running around the world, Cat Pumps is the supplier of choice for custom pumping systems.



## System Configuration

With extensive experience building thousands of systems, Cat Pumps can help determine the best configuration for any application.

### Base

System design starts with choosing the base that best fits the application. Numerous base configurations are available to meet space, portability, sound and material demands.

- Standard • Vertically Stacked • Enclosed • Multiple Pump

### Power Source

A qualified technical staff with extensive experience can assist in recommending the correct product for any power source available.

- Electric • Gas • Diesel • Hydraulic • Pneumatic

### Drive Package

A wide variety of drive packages are available to complement any power source of choice.

- Belt • Direct Drive • Gearbox • Clutch

### Accessories

Choose from hundreds of high-quality genuine Cat Pumps accessories for optimum system performance and life.

- Regulator • Relief / Pop-off Valve • Pressure Gauge • Pulsation Dampener • Inlet Filter / Strainer • Oil

## Advanced Control Options



Ask about advanced control options designed to provide maximum system performance as well as system protection. Options include:

- Variable Frequency Drives (VFD)
- PID Loop (varies speed of pump to maintain system pressure)
- Multiple Pump Systems
- Low-Pressure Seal Monitors
- Auto Shutdowns (Temperature and Low Inlet Pressure)

Other control options are available upon request.

# Accessories

## Pressure Regulators

### Standard Models

Model	Flow Range		Pressure Range	
	gpm	lpm	psi	bar
7001	0.5 - 5	1.9 - 19	100 - 1000	7 - 70
7002	0.5 - 5	1.9 - 19	500 - 2000	35 - 140
7003	0.5 - 5	1.9 - 19	1500 - 3000	105 - 210
7011	1 - 10	3.8 - 38	100 - 1000	7 - 70
7012	1 - 10	3.8 - 38	500 - 2000	35 - 140
7013	1 - 10	3.8 - 38	1500 - 3000	105 - 210
7021	2.5 - 25	9.5 - 95	100 - 1000	7 - 70
7022	2.5 - 25	9.5 - 95	500 - 2000	35 - 140
7023	2.5 - 25	9.5 - 95	1500 - 3000	105 - 210
7031	3.5 - 35	13.2 - 132	250 - 1000	18 - 70
7032	3.5 - 35	13.2 - 132	1000 - 2000	70 - 140
7033	3.5 - 35	13.2 - 132	1500 - 3000	105 - 210
7590.100	10 - 52	38 - 198	400 - 2175	28 - 150



7001

### 316 Stainless Steel Models

7001.100	0.5 - 5	1.9 - 19	100 - 1000	7 - 70
7002.100	0.5 - 5	1.9 - 19	500 - 2000	35 - 140
7003.100	0.5 - 5	1.9 - 19	1500 - 3000	105 - 210
7011.100	1 - 10	3.8 - 38	100 - 1000	7 - 70
7012.100	1 - 10	3.8 - 38	500 - 2000	35 - 140
7013.100	1 - 10	3.8 - 38	1500 - 3000	105 - 210
7021.100	2.5 - 25	9.5 - 95	100 - 1000	7 - 70
7022.100	2.5 - 25	9.5 - 95	500 - 2000	35 - 140
7023.100	2.5 - 25	9.5 - 95	1500 - 3000	105 - 210
7031.100	3.5 - 35	13.2 - 132	250 - 1000	18 - 70
7032.100	3.5 - 35	13.2 - 132	1000 - 2000	70 - 140
7033.100	3.5 - 35	13.2 - 132	1500 - 3000	105 - 210
7375	10 - 75	38 - 284	100 - 1000	7 - 70
7376	10 - 75	38 - 284	500 - 2000	35 - 140



7001.100

## Pressure Guages

### Bottom-mount Models

Model	Max psi	bar	Fitting	Port
6086	1500	105	Brass	1/4" NPT(M)
6088	3000	210	Brass	1/4" NPT(M)
6085	1500	105	316 Stainless	1/4" NPT(M)
6097	3000	210	316 Stainless	1/4" NPT(M)



6088

# Accessories

## Relief Valves

### Brass Models

Model	Flow Range		Pressure Range	
	gpm	lpm	psi	bar
7190	0 - 6.5	0 - 25	400 - 5000	28 - 345
7620.100	0.5 - 7.8	1.9 - 30	100 - 3145	7 - 220
7630.100	2 - 10	8 - 40	400 - 5100	28 - 350
7694.100	2.5 - 10.5	9.5 - 40	400 - 4050	28 - 280
7542.100	1 - 21	3.8 - 80	800 - 4000	55 - 275
7595	1 - 53	3.8 - 200	260 - 2600	18 - 180



7595

### 316 Stainless Steel Models

7501.100	.5 - 6	1.9 - 23	100 - 2000	7 - 140
7034	1 - 21	3.8 - 38	400 - 2200	28 - 155
7036	1 - 21	3.8 - 38	800 - 4000	55 - 275
890709	20 - 60	76 - 227	1500 - 4000	105 - 275
890700	30 - 180	114 - 680	1000 - 3000	70 - 210



7036

## Pulsation Dampeners

### 316 SS Fitting with Carbon Steel Body, Sealed, Fixed Precharge

Model	Max Flow		Pressure Range		Bladder Material	Volume Cubic Inches	Precharge psi
	gpm	lpm	psi	bar			
6026	15	57	300 - 600	20 - 41	NBR	10	250
6028	15	57	600 - 1000	41 - 70	NBR	10	450



6028

### 316 SS Fitting with Carbon Steel Body, Adjustable Precharge, Rechargeable

6029	15	57	100 - 3000	7 - 210	NBR	10	450
6010	40	151	100 - 3000	7 - 210	NBR	45	450
6012	70	265	100 - 1500	7 - 105	NBR	120	450

Note: Optimal pre-charge should be preset to 50% of operating pressure. To change pre-charge, add .800 to part number and specify pre-charge.



6010

### 316 Stainless Steel Fitting and Body, Adjustable Precharge, Rechargeable

6031	15	57	100 - 2400	7 - 168	NBR	10	450
6014	25	95	100 - 2400	8 - 168	NBR	20	450
6013	40	151	100 - 2000	7 - 140	FPM	45	450
6015	70	265	100 - 1500	7 - 105	NBR	120	450

Note: Optimal pre-charge should be preset to 50% of operating pressure. To change pre-charge, add .800 to part number and specify pre-charge.



6031

## ABOUT CAT PUMPS

## Proven Quality, Customer Focused

Founded in 1968, Cat Pumps is a world leader in the design, manufacture and marketing of the most dependable high-pressure positive displacement reciprocating triplex pumps and systems in the market.

With an emphasis on immediate product availability and outstanding customer service, the family-owned and operated business prides itself on a commitment to quality and product reliability as the foundation of its ongoing success. It is the mission to exceed customer expectations for quality, reliability, availability, delivery, technical expertise and aftermarket support to assure the best value in all the industries served.

## LOCATIONS

### Worldwide Headquarters

#### Cat Pumps

1681 94th Lane Northeast  
Minneapolis, MN 55449  
USA

P: 763-780-5440  
F: 763-780-2958  
techsupport@catpumps.com  
www.catpumps.com

#### Territories Served

U.S., Canada

#### International Division

P: 763-780-5440  
F: 763-780-2958  
intlsales@catpumps.com  
www.catpumps.com

#### Territories Served

Africa, Asia, Australia, Central and South America, Mexico, Middle East, New Zealand, Turkey

#### Cat Pumps International N.V.

Heiveldekens 6A  
2550 Kontich  
Belgium

P: 32 3 450 71 50  
F: 32 3 450 71 51  
cpi@catpumps.be  
www.catpumps.be

#### Territories Served

Western Europe (except U.K., Germany, and Austria)

#### Cat Pump (U.K.) Ltd.

1 Fleet Business Park, Sandy Lane  
Church Crookham  
FLEET, Hampshire GU52 8BF  
England

P: +44 1252 622031  
F: +44 1252 626655  
sales@catpumps.co.uk  
technical@catpumps.co.uk  
www.catpumps.co.uk

#### Territories Served

England, Ireland, Scotland,  
N. Ireland, Wales

#### Cat Pumps Deutschland GmbH

Buchwiese 2, D-65510  
Idstein  
Germany

P: +49 6126 9303 0  
F: +49 6126 9303 33  
catpumps@t-online.de  
www.catpumps.de

#### Territories Served

Austria, Commonwealth of Independent States (CIS), Germany and Eastern Europe

## SALES, DISTRIBUTION, SERVICE

Call today for product and application assistance.  
763-780-5440 or visit us at [www.catpumps.com](http://www.catpumps.com)



#### CAT PUMPS

1681 - 94TH LANE N.E. MINNEAPOLIS, MN 55449-4324  
PHONE (763) 780-5440 — FAX (763) 780-2958  
e-mail: techsupport@catpumps.com  
www.catpumps.com