

XD-Series Plunger Pumps

Exceptional Performance in Deionised (DI) Water Applications



XD SERIES

Product Quality, Reliability and Support You Expect

www.catpumps.co.uk



The Cat Pumps XD-Series Advantage

Innovative Seal Design Promotes Longevity, Less Maintenance and More Uptime

Applications like high-pressure turbine fogging and misting systems demand equipment that thrives in harsh environments, with minimal operator attention. The Cat Pumps XD-Series is designed to keep your system running reliably while reducing downtime and maintenance.

At the core is Cat Pumps' most advanced seal technology — X-Series extended-life high-pressure packings and a proprietary low-pressure seal blend engineered for low-lubricity fluids, such as deionised (DI) water. This combination eliminates the need for freshwater flushing, reducing system complexity, lowering operating costs, and preventing premature wear.

Whether the application is turbine inlet cooling, data centre climate control, greenhouse misting or dust suppression, the XD-Series delivers rugged performance and long-term value in uptime, efficiency, and total cost of ownership.



Engineered from the Packings Out for Extended Life with Deionised Water

Cat Pumps XD-Series models are precision-built to deliver unmatched performance and extended service life in demanding fogging and misting systems. Every design feature serves a purpose — keeping pumps running longer with less service, even in applications that use aggressive deionised (DI) water.

XD-Series Seal Technology

Special blended low-pressure seals engineered for low-lubricity fluids eliminate the need for manifold flushing in DI water applications

X-Series High-Pressure Packings

Reduce friction and heat for longer seal life up to 3x longer than traditional seals

Corrosion-Resistant Stainless Steel Wet-Ends

Cast 316 stainless steel manifolds and internal components provide maximum durability against harsh ultra-pure water

High-Strength Connecting Rods and Plunger Rods

Built for continuous-duty performance in rugged applications, even at low RPMs

Exclusive Internal Crankcase Oil Porting

Delivers critical lubrication to the crossheads, reducing internal wear, especially during long, steady run times

Precision 316 Stainless Steel Valve Assemblies

Designed for reliable seating, low pressure loss and long-term operation

Proven Wet Seal Design

Keeps seals internally cooled and lubricated — ideal for low-lubricity DI water use

Built for Demanding, Ultra-Pure Deionised Water Operation

Why Choose Cat Pumps XD-Series for Turbine Fogging and Misting?

- Extended seal life means fewer maintenance intervals and more uptime
- Specialised low-pressure seals eliminate freshwater flushing typically required for low-lubricity DI water
- Reduced maintenance and lower long-term operating costs
- Proven in turbine inlet cooling, greenhouse climate control, dust suppression and other high-precision misting applications
- Supported by Cat Pumps' global service and stocking network
- Built for true 24/7/365 continuous-duty performance

Proven in the Field — Trusted Worldwide

From power plants to agricultural operations, Cat Pumps XD-Series models are trusted in mission-critical environments where failure is not an option. Cat Pumps' reputation for reliability is backed by rigorous in-house life testing and decades of real-world performance.

Operators choose Cat Pumps because they have one less thing to worry about. With the XD-Series, they get more uptime, fewer service calls, and pumps that keep working when others fail.

Quality You Need to Keep Your Fogging System Running

Cat Pumps offers a wide range of XD-Series pump models and configurations to meet turbine fogging and misting requirements:

- **Seal Materials:** Proprietary XD low-pressure seals and advanced high-pressure packings for maximum life in DI water use
- **Flow Range:** 38 to 170 lpm
- **Pressure Range:** Up to 152 bar depending on model
- **Manifold Materials:** 316 stainless steel for superior corrosion resistance

XD SERIES

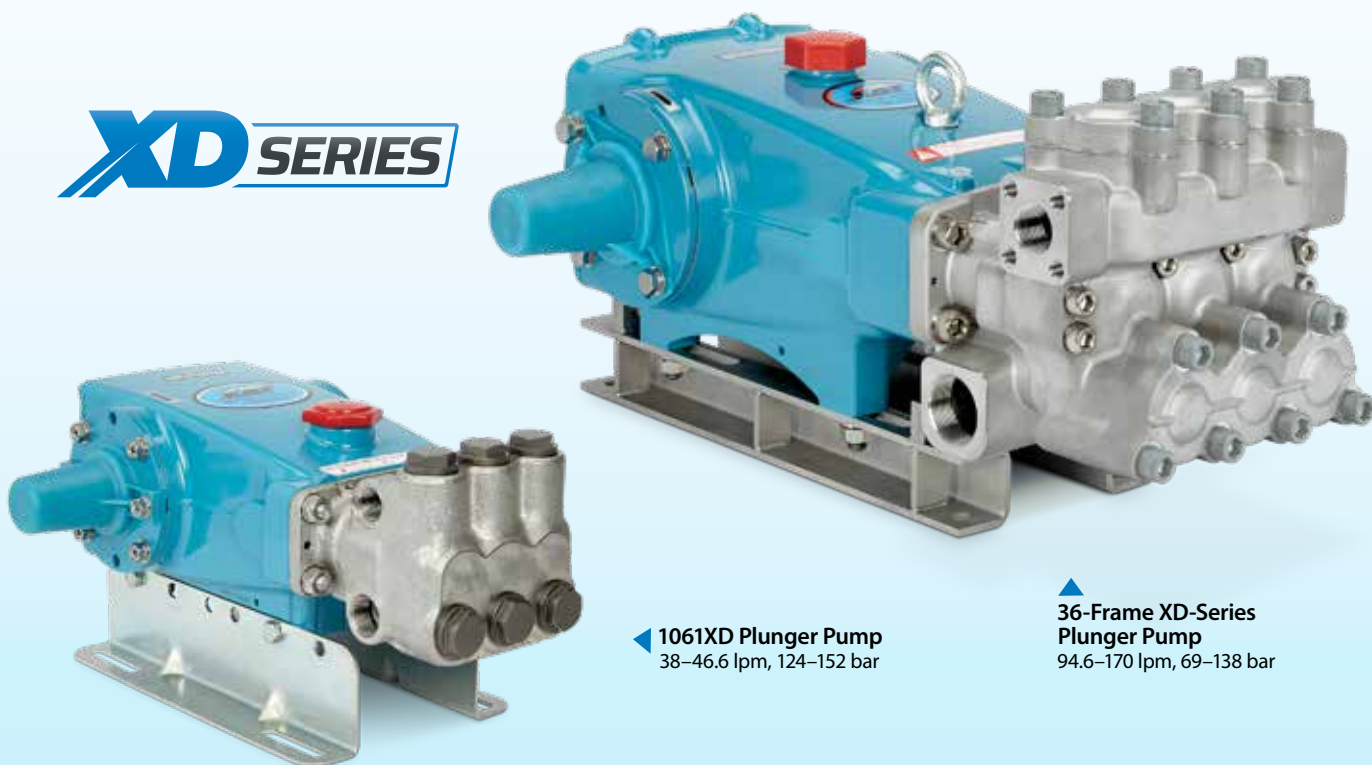

◀ **1061XD Plunger Pump**
38–46.6 lpm, 124–152 bar

▲ **36-Frame XD-Series Plunger Pump**
94.6–170 lpm, 69–138 bar

The XD-Series Advantage

Built Stronger. Runs Longer. Engineered to Be the Best Pumps You'll Ever Own.

Manifolds and Valve Plate Covers (36-Frame XD-Series Only)

- New manifold and valve plate cover design eliminates threaded stainless steel valve plugs — no seized threads, no special tools, faster service in the field.
- 316 stainless steel construction offers superior corrosion resistance.

Plunger Sleeves (36-Frame XD-Series Only)

- Delrin sleeves create a protective barrier between the ceramic plunger and packing spring, reducing unswept volume and internal wear.
- This added separation enhances seal performance and extends the service life of both plungers and packings.

Seals

- X-Series high-pressure packings offer proven durability and consistent performance in DI water fogging systems.
- Specialised low-pressure seals in the XD models are engineered for low-lubricity fluids, such as deionised water, eliminating the need for freshwater flushing.
- Original wet-seal design lubricates from the inside, reducing wear and extending seal life in demanding applications.
- Seal kits and wear parts are stocked for same-day shipping, minimising downtime and inventory requirements.

Valves

- Precision-machined for reliable sealing, low pressure loss and reduced cavitation.
- 316 stainless steel construction provides excellent corrosion resistance and long service life.
- Designed for easy access and fast field servicing to minimise downtime.

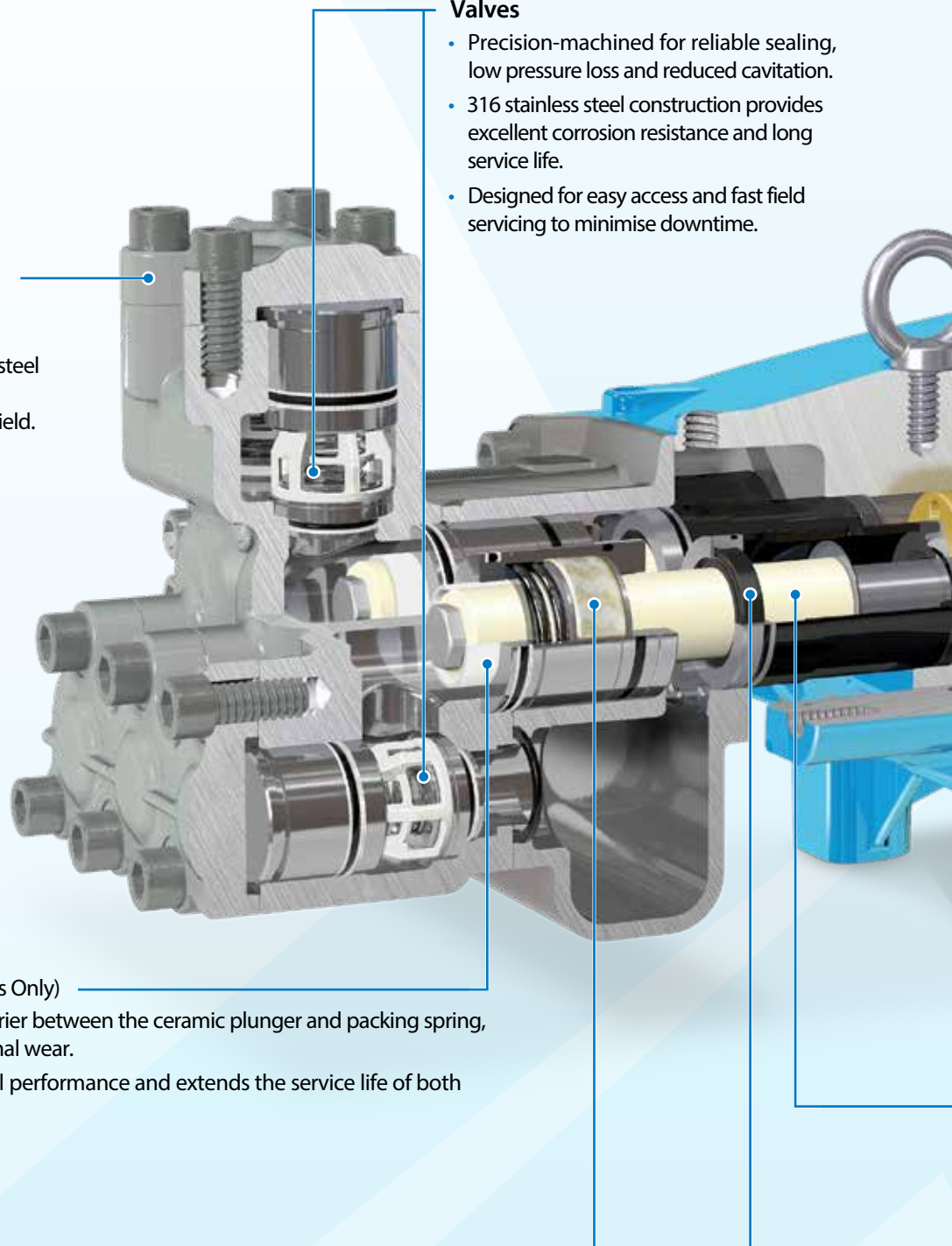

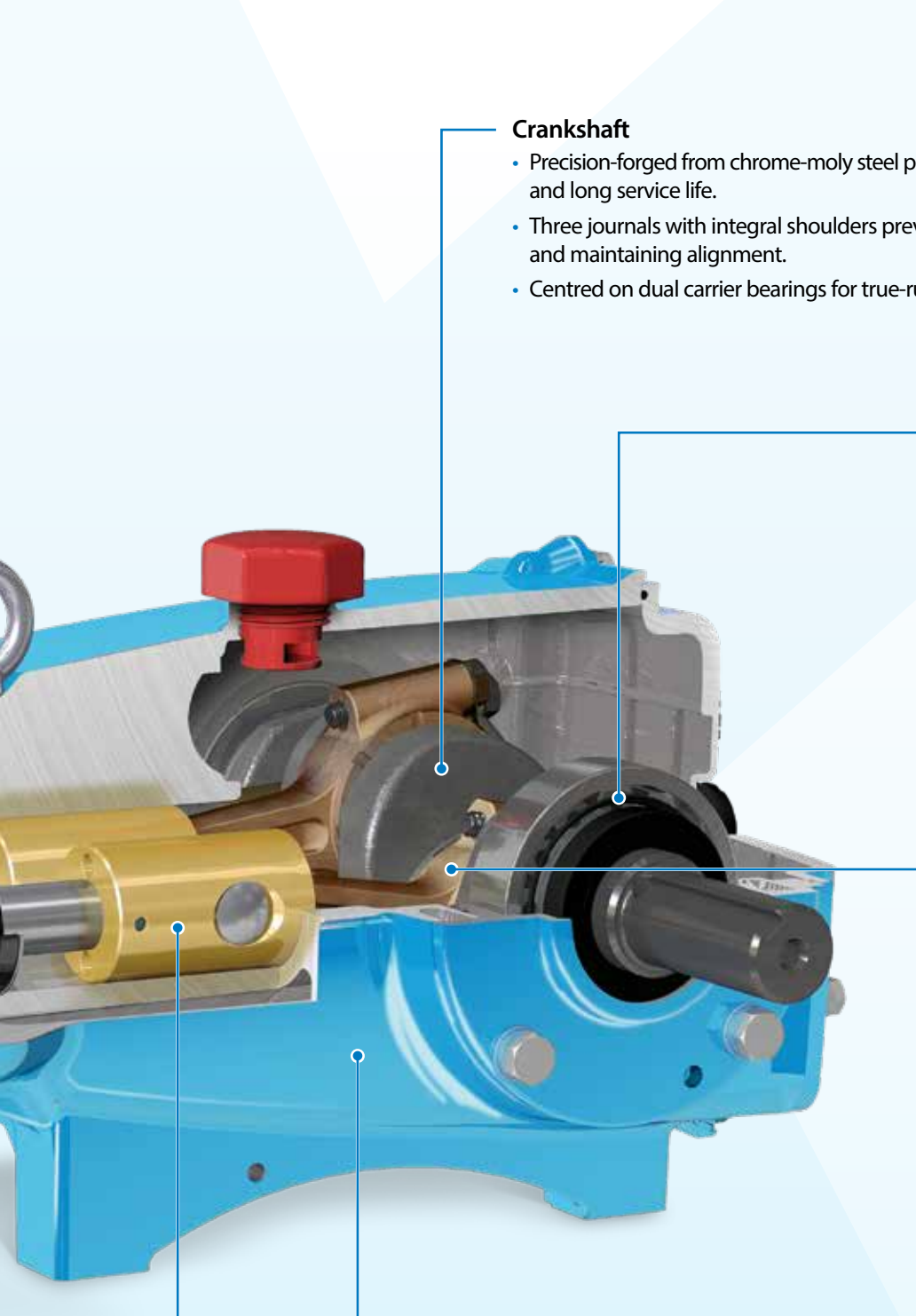

Crankshaft

- Precision-forged from chrome-moly steel provides exceptional strength, wear resistance and long service life.
- Three journals with integral shoulders prevent lateral drift, reducing internal wear and maintaining alignment.
- Centred on dual carrier bearings for true-running support across the drive-end.

Bearings

- Bearing design and style are optimised for the power range of each pump frame size, increasing performance and reliability.
- Oversized premium bearings greatly extend bearing life, with same bearing style used on both sides of crankshaft. The mechanical integrity of Cat Pumps' bearing design is unmatched in the industry.

Connecting Rods

- Matched oversized connecting rods are cast from a high-strength alloy engineered for dimensional stability and long-term durability.
- Material blend offers excellent damping and vibration control, ideal for heavy-duty performance.
- Hardened surfaces and robust geometry eliminate the need for bearing inserts or sleeves, reducing wear and simplifying service.

Crankcase

- Rugged, die-cast aluminium design combines high strength and low weight, with splash lubrication for reliable operation down to 100 RPM.
- Advanced geometry promotes oil flow and cooling, extending drive-end life in continuous-duty applications.
- Finished with a two-coat electrostatic paint process, primer and blue epoxy, for superior resistance to water, chemicals and harsh environments.
- Outperforms anodising and other less expensive coatings while providing lasting protection and a signature Cat Pumps appearance.

Plunger Rods

- 316 stainless steel rods paired with brass (36-Frame) or bronze (1061XD) crossheads deliver superior wear resistance and mechanical strength.
- Fully guided plunger rod heads run with 360° support in the crankcase bore for precise alignment and reduced wear.
- Cat Pumps-exclusive internal oil porting system directs lubrication to the front side of the crosshead, ensuring full-time protection at any speed.
- Optimised crankcase and oil flow design allows smooth, reliable operation down to 100 RPM, ideal for VFD applications.

Plungers

- Solid ceramic plungers are precision-polished and concentric for a true wear surface and maximum seal life.
- High-density ceramic construction resists thermal shock and abrasion in continuous-duty applications.
- Graphite-impregnated surfaces reduce friction, lowering seal wear and extending service intervals.

Specifications & Accessories

XD-Series Specifications

MODEL	MATERIAL	FLOW	MAX PRESSURE	RPM	INLET PRESSURE RANGE	MAX LIQUID TEMP	INLET PORTS (2)	DISCHARGE PORTS (2)
1061XD	316 SS	38 lpm	152 bar	958	-0.35 to 4.1 bar	70° C 160° F	¾" NPT(F)	½" NPT(F)
1061XD (Alternate)	316 SS	46.6 lpm	124 bar	1180	1.4 to 4.1 bar	38° C 100° F		
3621XD	316 SS	94.6 lpm	138 bar	870	Flooded to 4.8 bar	60° C 140° F	1½" NPT(F)	1" NPT(F)
3631XD	316 SS	136 lpm	83 bar	800				
3641XD	316 SS	170 lpm	69 bar	765				

Popular 15-Frame XD-Series Accessories



Pressure Regulator
PN 7021
9.4 – 94.6 lpm
103 – 207 bar



Pop-Off Valve
PN 9941
0 – 94.6 lpm
69 – 276 bar



Pressure Gauge
PN 6097
0 – 207 bar



Pulsation Dampener
PN 1621SS180
Up to 45 lpm
0 – 165 bar



Crankcase Oil
PN 6132
1 Litre
Specially-Formulated
for Extended Protection

Popular 36-Frame XD-Series Accessories



Pressure Regulator
PN 7376
38 – 285 lpm
35 – 138 bar



Pop-Off Valve
PN 9952
0 – 189 lpm
35 – 138 bar



Pressure Gauge
PN 6097
0 – 207 bar



Pulsation Dampener
PN 7210SS
Up to 150 lpm
0 – 140 bar



Crankcase Oil
PN 6133
4 Litres
Specially-Formulated
for Extended Protection

Engineered Pump Packages. You Define. We Design.

At Cat Pumps U.K. Limited, we have been dedicated to helping customers with their unique applications for over half a century. Cat Pumps are built to last and are well known for their reliability, durability and versatility; serving a wide range of industries and applications. Cat Pumps is an industry leader in providing customers with quality custom-engineered pumping systems to meet a wide range of application needs, with the following options available:

Electric Motors

There are number of options available.

Drive Systems

Our pumps can be connected to a motor in a variety of ways.

Base or Frame Configuration

We can mount the pump package simply on a base plate or on a frame designed specifically to meet your installation needs and space envelope.

Motor Controls

To control the pump package, we can supply DOL or VSD controls configured to meet your exacting requirements.

Pump Package Accessories

To compliment the Cat Pumps pump package, we can supply a multitude of pump accessories.



ATEX Pumps and Pump Packages

Cat Pumps offer ATEX High Pressure Pumps and Pump packages to suit applications in an explosive atmosphere. Cat Pumps have over 30 years of experience designing, building and testing ATEX pump packages for use in zones 1 and 2 and meets the requirement of ATEX 114 "equipment" Directive 2014/34/EU — Equipment and protective systems intended for use in potentially explosive atmospheres. All Cat Pumps ATEX HP Pump packages are fully tested and supplied with certification that ensures that the equipment is fit for its intended purpose and that adequate information is supplied with it to ensure that it can be used safely.



ABOUT CAT PUMPS

Proven Quality, Customer Focused

Cat Pumps is the world leader in the design, manufacture and marketing of the most dependable high-pressure positive displacement reciprocating triplex pumps and systems in the market. Our mission to exceed customer expectations for quality, reliability, availability, delivery, technical expertise and aftermarket support to assure the best value in all the industries served.

LOCATIONS

Worldwide Headquarters

Cat Pumps

1681 94th Lane Northeast
Minneapolis, MN 55449
USA

P: (763) 780-5440
F: (763) 780-2958
techsupport@catpumps.com
www.catpumps.com

Territories Served

U.S., Canada

International Division

P: (763) 780-5440
F: (763) 785-4329
intlsales@catpumps.com
www.catpumps.com

Territories Served

Africa, Asia, Australia, Central and South America, Mexico, Middle East, New Zealand, Turkey

Cat Pumps International N.V.

Heiveldekens 6A
2550 Kontich
Belgium

P: 32 3 450 71 50
F: 32 3 450 71 51
cpi@catpumps.be
www.catpumps.be

Territories Served

Western Europe (except U.K., Germany, and Austria)

Cat Pump (U.K.) Ltd.

1 Fleet Business Park, Sandy Lane
Church Crookham
FLEET, Hampshire GU52 8BF
England

P: +44 (0)1252 622031
F: +44 (0)1252 626655
sales@catpumps.co.uk
www.catpumps.co.uk

Territories Served

U.K. and Ireland

Cat Pumps Deutschland GmbH

Buchwiese 2, D-65510
Idstein
Germany

P: +49 6126 9303 0
F: +49 6126 9303 33
catpumps@t-online.de
www.catpumps.de

Territories Served

Austria, Commonwealth of Independent States (CIS), Germany and Eastern Europe

SALES, DISTRIBUTION, SERVICE

Call today for product and application assistance.
+44 (0) 1252 622031 or visit us at www.catpumps.co.uk



CAT PUMPS (U.K.) LTD.

1 FLEET BUSINESS PARK, SANDY LANE, CHURCH CROOKHAM
FLEET, HAMPSHIRE GU52 8BF, ENGLAND
P: +44 1252 622031 • F: +44 1252 626655
sales@catpumps.co.uk • www.catpumps.co.uk

For International inquiries go to www.catpumps.co.uk and navigate to the "Contact Us" link.

©2026 Cat Pumps Inc. All rights reserved. All written and visual data contained in this document are based on the latest product information available at the time of publication. Cat Pumps reserves the right to make changes at any time without notice. All other brand names or marks are used for identification purposes and are trademarks of their respective owners.